

 **Sealed Air**

Fill-Air[®] 2000

Inflatable Packaging System

The Fast, User-Friendly, Packaging System Designed To Be On-Line All The Time



Material stand not included.

Fill-Air® 2000 Inflatable Packaging System

Create Variable Cushion Sizes with Unmatched Speed and Ease of Use

Fast, Efficient, Void Fill Packaging



The Fill-Air® 2000 system is Sealed Air's premier void fill packaging solution. The Fill-Air® 2000 system creates inflatable packaging on demand, at a speed of up to 200 cushions per minute. Increased speed and throughput make the Fill-Air® 2000 system the easy choice for on-line packaging operations.

Convenient and Versatile Inflatable Packaging

The Fill-Air® 2000 system creates cushions in six different sizes, with the ability to change between 4" and 8" lengths at the touch of a button. Our landscape sizes, such as the 12" x 4" cushion, fill small voids more efficiently.



Easy To Use

The Fill-Air® 2000 system features a user-friendly control pad, allowing operators to quickly select the ideal cushion size. Cushion sizes can be changed mid-production without changing the film roll, saving time and warehouse space.

Maintenance is quick and easy, with sealing components that snap into place.

Create various cushion sizes with the Fill-Air® 2000 system.

Ideal For On-Line Applications

Integrating the Fill-Air® 2000 system into a packaging line is simple and efficient. The system is all-electric; no shop air is required, making it easy to install in any packaging location. The auto-replenishment sensor maintains a constant supply of cushions, ensuring that material is readily available. The optional material stand allows the operator to position the material directly above the cartons to be packed.

Increase Productivity, Reduce Systems

One Fill-Air® 2000 system can support multiple packaging stations or multiple packaging lines. Multiple packaging lines can converge into a single, centralized line serviced by one Fill-Air® 2000 system. Likewise, material can be collected in bins and distributed to packaging stations, or it can be conveyed through a Sealed Air engineered overhead delivery system.

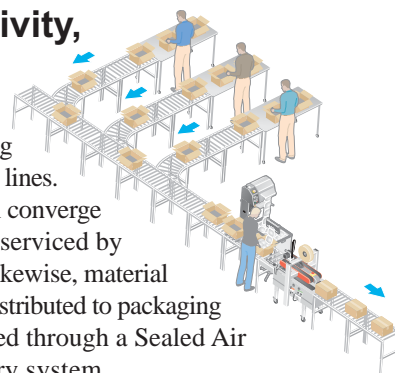

Specifications

Electrical:
100-120 VAC~ Single Phase
7 Amp 50/60 Hz

Weight (without roll):
199 lbs. 90 Kg.

Overall Size (W x D x H):
32" x 30" x 58"
.81m x .76m x 1.47m

Optional Bin: 36" x 21" x 29"

Film	Width	Length
FA2K-200	8"/20cm	3,000'/914m
FA2K-250	10"/25cm	3,000'/914m
FA2K-300	12"/30cm	2,500'/762m

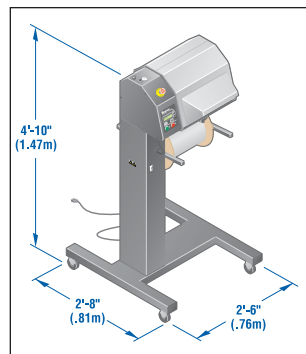

Distributed by:



Protective Packaging
301 Mayhill Street
Saddle Brook, NJ 07663-5303
800-648-9093 Fax: 201-712-7070
www.fillair2000.com

Our Products Protect Your Products®

Corporate Office: Sealed Air Corporation (US)
200 Riverfront Boulevard, Elmwood Park, NJ 07407 www.sealedair.com
© Reg. U.S. Pat. & TM Off. © Sealed Air Corporation (US) 2006. All rights reserved. Printed in the U.S.A.
The "9 Dot Logo" and "Sealed Air" are registered trademarks of Sealed Air Corporation (US).